

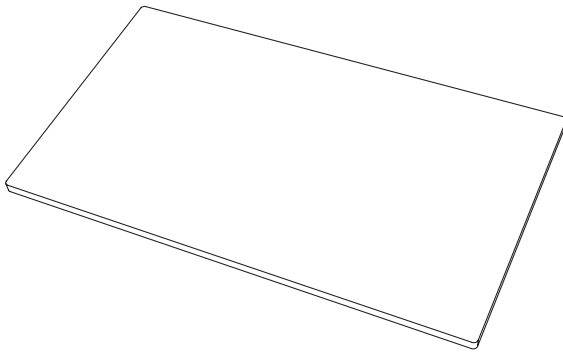

---

## Black 60" x 24" Table Top

Instruction Manual



**SKU: DESK-TOP60B**



Scan the QR code with your mobile device or follow the link for helpful videos and specifications related to this product.

**<https://vivo-us.com/products/desk-top60b>**

---

GET IN TOUCH | Monday-Friday from 7:00am-7:00pm CST



help@vivo-us.com



www.vivo-us.com  
*Chat live with an agent!*



309-278-5303

## WARNING!

If you do not understand these directions, or if you have any doubts about the safety of the installation, please call a qualified technician. Check carefully to make sure there are no missing or defective parts. Improper installation may cause damage or serious injury. Do not use this product for any purpose that is not explicitly specified in this manual and do not exceed weight capacity. We cannot be liable for damage or injury caused by improper mounting, incorrect assembly, or inappropriate use.

### PACKAGE CONTENTS

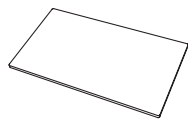

A (x1)  
Desktop

### TOOLS NEEDED

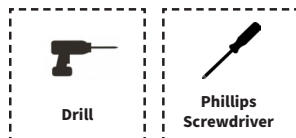

Drill

Phillips  
Screwdriver

### ASSEMBLY STEPS

#### STEP 1

Mount the desktop to the desk frame using screws. If necessary, drill pilot holes for the screws to match your desk frame. If using a VIVO desk frame, make sure to orientate the desktop so the control panel or crank handle pilot holes are facing the front.



Please note that mounting screws are not included with this desktop. Use the mounting hardware included with your standing desk frame to mount the desktop.

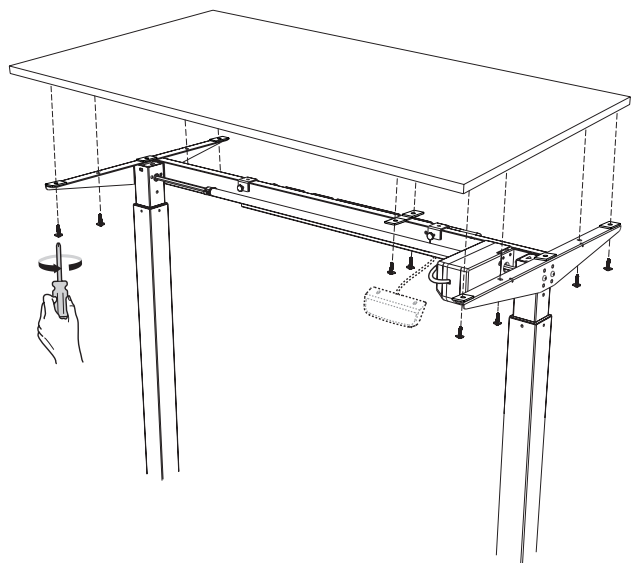

This desktop is pre-drilled to match the mounting holes in most VIVO electric desk frames with two legs. Some frames will not fit these holes. In this case, you will need to drill your own to match your frame.

#### STEP 2

For VIVO frames, pre-drilled holes have been included for most control panels and crank handles.

Note that holes for some control panels and cranks are not pre-drilled. In this case, you must drill your own.

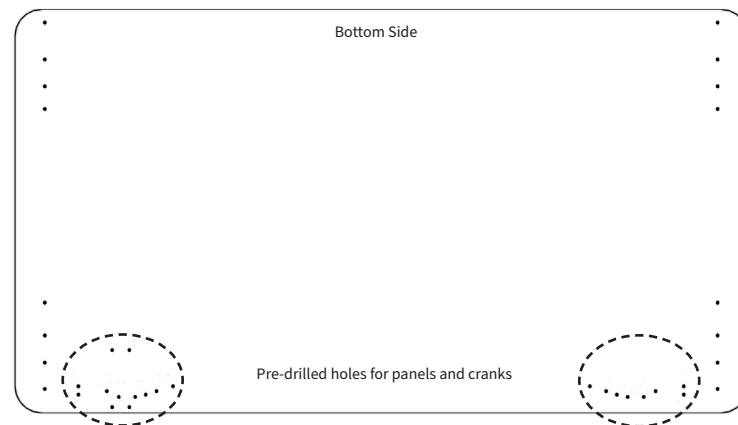

#### STEP 3

Use a bubble level to make sure the desktop is level. If necessary, adjust the foot pads on the standing desk frame to level the desktop.

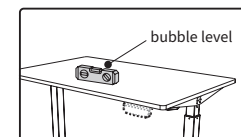
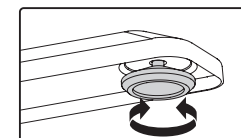

#### STEP 4

If installed to an electric height adjustable desk frame, the desk may now be plugged into a power outlet.

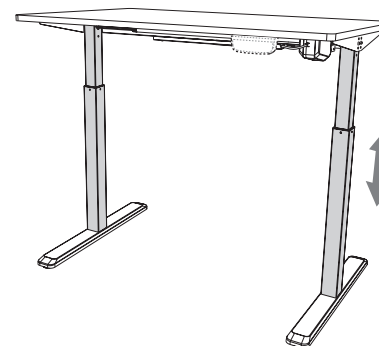
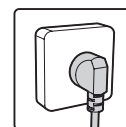



Love your new VIVO setup and want to share?  
Tag us in your photo! [@vivo\\_us](#)

LAST UPDATED: 04/12/2022  
REV4



Open **Monday - Friday 7:00am - 7:00pm** CST,  
our dedicated support team can offer immediate assistance with rapid response times. If any parts are received damaged or defective, please contact us. We are happy to replace parts to ensure you have a fully functioning product.



309-278-5303

**AVG. RESOLUTION TIME** (*within office hrs*): **5M 4S**



[www.vivo-us.com](http://www.vivo-us.com)  
*Chat live with an agent!*

**AVG. RESOLUTION TIME** (*within office hrs*): **< 15 M**



[help@vivo-us.com](mailto:help@vivo-us.com)

**AVG. RESPONSE TIME** (*within office hrs*): **1HR 8M**

- 23% within < 15m
- 38% within < 30m
- 61% within < 1hr
- 83% within < 2hr
- 92% within < 3hr

FOR MORE VIVO PRODUCTS, CHECK OUT OUR WEBSITE AT: [www.vivo-us.com](http://www.vivo-us.com)